

## S40 MODEL HORIZONTAL SHRINK WRAPPER



- ◆ 80 PACKAGES PER MINUTE
- ◆ COMPACT DESIGN
- ◆ FLEXIBLE PACKAGE SIZE RANGE
- ◆ EASY MAINTENANCE

**Platinum's S40 Model** Horizontal Shrink Wrapper is designed for operating speeds of up to 80 packages per minute. The compact design of the **S40 Model** saves valuable floor space while offering 5 feet of clear product feeding space.

Touch screen electronic controls provide fast and precise product changeover with 15 programmable product setups. Precise digital heat controls provide consistent end seal quality.

The unique EZ-SET end crimper phasing control

allows the operator to position the crimper between the product during initial setup, then easily fine tune the setting...while the machine is running.

The S40 Model can accommodate a variety of shrink films, including polyolefins as well as PVCs. It is surprisingly affordable and so versatile, it's ideal for a wide variety of food, pharmaceutical and general industrial applications.

# Platinum S40 Model Horizontal Shrink Wrapper

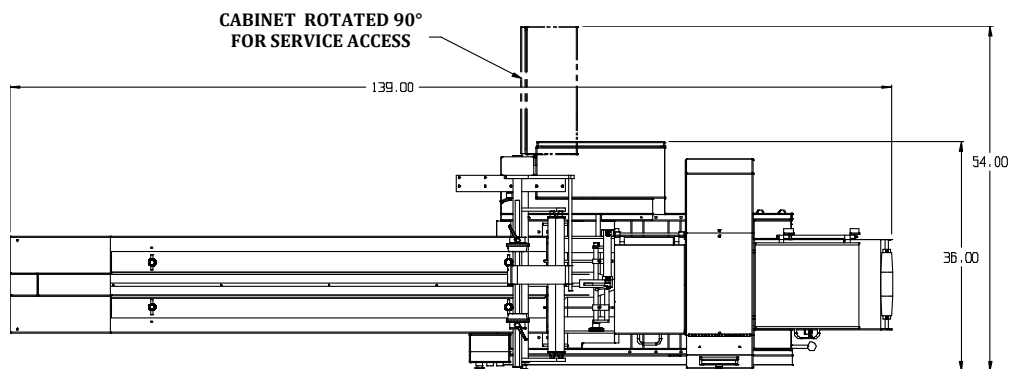

## SPECIFICATIONS

- **Machine Size**  
Length – 139”  
Width – 36”  
Height – 62”
- **Infeed Conveyor**  
Length – 92”  
Feed Space – 60”  
Height Above Floor – 37”
- **Wrapping Material**  
Maximum Parent Roll Diameter – 13”  
Roll Width – 20”  
1 Parent Roll
- **Lap Seal Assembly (Length Seal)**  
Static lap seal with vacuum belt
- **Product Discharge**  
Conveyor, 24” long
- **Touch Screen for Machine Controls**
- **Product Flow**  
Left to right, facing the control panel
- **Painted and Stainless Steel Finish**
- **Maximum Package Size**  
(Cannot be tolerated simultaneously)  
Length – 16”  
Width – 7”  
Height – 2-5/8” Standard
- **Electrical**  
1/2 HP AC Drive Motor  
230 V, 3 PH, 60 H
- **Maximum Mechanical Speed**  
90 Cycles Per Minute
- **Weight**  
900 lbs.



**Static Lap Seal**

- **End Crimper (Cross Seal)**  
1 – up x 10” wide standard

## OPTIONAL EQUIPMENT

- Expanded Spare Parts Kit
- Extended Infeed Conveyors

\* Specifications subject to change without notice.