

THE PLATINUM PACKAGING GROUP

150s MODEL SERVO CONTROLLED HORIZONTAL WRAPPER



- ◆ **SPEED TO 150+
PACKAGES PER
MINUTE**
- ◆ **TOUCH SCREEN
CONTROL**
- ◆ **FLEXIBLE PACKAGE
SIZE RANGE**
- ◆ **COMPACT DESIGN**

Platinum's 150s Model 3-axis Servo Controlled Horizontal Wrapper is designed for operating speeds to 150+ packages per minute with the flexibility and control available from servo controlled motors...and the Model 150s performs all these functions in a compact size.

A sharp, conveniently placed **Touch Screen** displays the status of the wrapper and offers fast access to the many features selectable through the touch screen. You may store settings for up to 30 different products that can be quickly recalled. Additional screens can be accessed to display maintenance information.

Platinum's 150s Model uses the Indramat system of Sercos controlled servomotors, one of the highest levels of machine control offered today. And this control is very flexible and can be expanded to talk with other Sercos controlled machines up or downstream from the Model 150s.

Many other features are included in the *new* 150s Model including a new infeed conveyor with stainless steel side skirting and new guarding over the fin seal and discharge conveyor area for improved accessibility. Optional features include no-product-no-bag and no-gap-no-seal. All this and more from the Platinum 150s Model.

THE
PLATINUM PACKAGING
GROUP

So. California Office:
7627 Somerset Blvd.
Paramount, CA 90723

tel: (562) 630-6700
fax: (562) 630-6716
email: info@platinumpkggroup.com

Platinum 150s Model Horizontal Wrapper

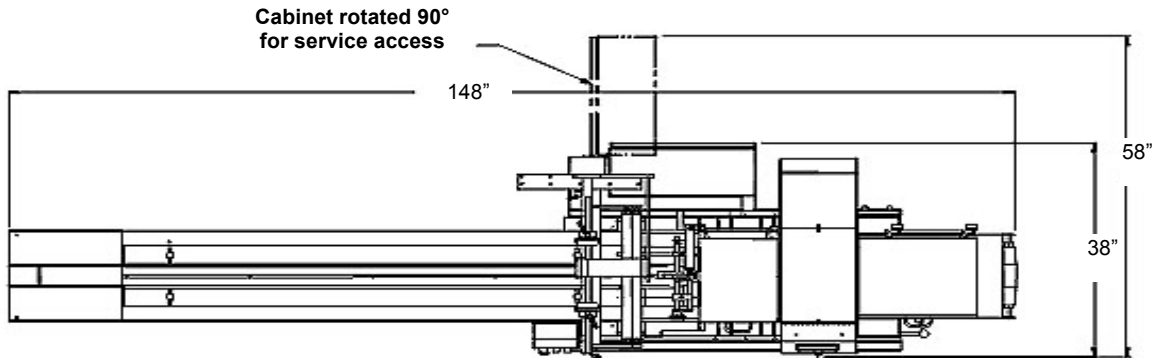

SPECIFICATIONS

- **Machine Size**
Length – 148"
Width – 38"
Height – 58"
- **Infeed Conveyor**
Length – 92"
Feed Space – 60"
Height Above Floor – 37"
- **Wrapping Material**
Maximum Parent Roll Diameter – to 13"
Roll Width – 20"
1 Parent Roll
- **Fin Seal Assembly (Length Seal)**
First Set – Pulling
Second Set – Sealing
Third Set – Pulling and fin turn over
- **End Crimper (Cross Seal)**
1 - up x 8" wide standard
- **Product Discharge**
Conveyor, 24" long
- **Three Heat Controllers**
Digital
- **Product Flow**
Left to right, facing the control panel
- **Polyurethane Finish**
- **Maximum Package Size**
(Cannot be tolerated simultaneously)
Length – 16"
Width – 8"
Height – 2 5/8" Standard
Larger sizes available
- **Electrical**
230 V, 3 PH, 60 H, 30 amps
- **Maximum Mechanical Speed**
150+ Cycles Per Minute
- **Weight**
1800 lbs.

OPTIONAL EQUIPMENT

- No-Product-No-Bag
- Expanded Spare Parts Kit
- No-Gap-No-Seal
- Printed Film Registration



TOUCH SCREEN

Quick and easy access to full machine control

* Specifications subject to change without notice.